



COLFEST

**EL PODER
DE LA PRECISIÓN**

THE POWER OF PRECISION



COL +57 (5) 339 5617
CALLE 41 # 52 - 75
BARRANQUILLA, ATLÁNTICO
080003
WWW.COLFAST.COM.CO
ADMON@COLFAST.COM.CO



ÍNDICE

INDEX

02	ICONOGRAFÍA / ICONOGRAPHY
03	SOBRE NOSOTROS / ABOUT US
09	MISIÓN / MISSION
15	VISIÓN / VISION
21	NUESTROS PRODUCTOS / OUR PRODUCTS
23	GRAPA / STAPLES
24	CLAVOS / NAILS
25	BRADS / BRADS
27-29	CLAVOS EN BOBINA ALAMBRE / WIRE COIL NAILS
31	ALTA PRESIÓN / HIGH PRESSURE
33	GRAPAS MEDIANAS / HEAVY DUTY WIRE STAPLE
35	GRAPAS LIGERAS / FINE WIRE STAPLE
37	BRADS / BRADS
39-40	CLAVOS EN BOBINA ALAMBRE / WIRE COIL NAILS
41	CLAVOS ESPECIALES EN BOBINA PLÁSTICO / SPECIAL PLASTIC COIL NAILS
42	CLAVO BOBINA PLÁSTICO / PLASTIC COIL NAILS
43	CLAVOS EN PEINE / STRIP NAIL
44-45	ALTA PRESIÓN / HIGH PRESSURE
46	SIERRA SABLE / SAW BLADES
47	CONTACTO / CONTACT



ICONOGRAFÍA / ICONOGRAPHY

PODER, CALIDAD Y PRECISIÓN

POWER, QUALITY & PRECISION



CIERRE DE BOLSAS
BAG CLOSURE



ATAUDES
COFFINS



CALZADO
FOOTWEAR



PALLETS
ESTIBAS



EMBALAJE DE CARTÓN
CARDBOARD PACKAGING



PELETERÍA
LEATHERWORKING



CONSTRUCCIÓN
CONSTRUCTION



PUERTAS
DOORS



EBANISTERÍA Y MUEBLES
WOODWORK & FURNITURE



CARPINTERÍA
CARPENTRY



EMBALAJE DE MADERA
WOODEN PACKAGING



TAPICERÍA
UPHOLSTERY



ESQUELETAJE
WOOD STRUCTURES



MARQUETERÍA
MARQUETRY



INDUSTRIA EN GENERAL
INDUSTRY IN GENERAL



VALLAS, VIVERO Y JAULAS
FENCES, GREENHOUSES & CAGES



COLCHONERÍA
MATTRESS

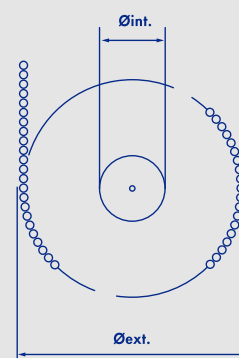

COLFAST
COLOMBIAN FASTENERS

La marca COLFAST es el socio más fiable para las industrias de embalajes, muebles, construcción y la industria automotriz.

Nuestras fijaciones y herramientas neumáticas están diseñadas para ofrecerte el mayor poder, precisión y fiabilidad del mercado.

Los sistemas de fijación COLFAST (Puntillas - Grapas - Pins - Brads), están fabricados con los altos estándares de calidad.

Nuestro objetivo es ofrecerle a nuestros clientes los mejores productos y una gran experiencia de servicio post venta.

The COLFAST brand is the most reliable partner for the packaging, furniture, construction and automotive industries.

Our fixings and pneumatic tools are designed to offer you the greatest power, precision and reliability in the market.

COLFAST fixing systems (Coil Nail - Staples - Pins - Brads), are manufactured to the highest quality standards.

Our goal is to offer our customers the best products and a great after-sales service experience.



COLFAST
CN70

ATENCIÓN

- Lea y entienda los avisos de los riesgos y el manual. El no seguir estas precauciones puede dar como resultado daños más graves.
- El usuario y los demás personal deben usar guantes de seguridad con protecciones laterales y protecciones de codo para evitar daños.
- Nunca use gases embudoables, por lo que se debe utilizar un tubo de escape regular de 2

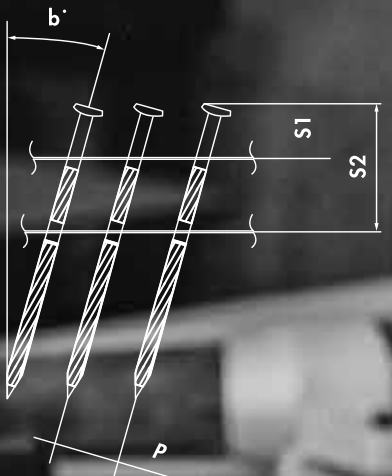

CN70 Clavadora en Bata

APLICACIONES: Fabricación y reparación de palets, bidones, embalajes y vallas de madera. Aplicación en general para la industria y la construcción.

ESPECIFICACIONES:

Peso	3,67 kg. (Cuerpo de Bata)
Capacidad cargador	225 - 300 clavos
Diámetro de clavo	2,5 - 2,9 mm
Largo de clavo	45 - 70 mm
Presión de trabajo	5 - 8,0 kgf/cm ²

18-07-30



En / At
COLFAST
COLOMBIAN FASTENERS

HACEMOS MÁS FÁCIL LOS PROCESOS INDUSTRIALES

WE MAKE
INDUSTRIAL PROCESSES
EASIER

MISIÓN

COLFAST es una marca especializada en fijaciones para la industria del mueble y la madera, distribuimos nuestros productos en toda Colombia, el caribe y centro américa. Nuestra misión es la de cada día hacer más fácil la labor de nuestros clientes en sus procesos industriales, aportándoles productos de excelente calidad.

COLFAST se compromete a ofrecerles el mejor servicio y atención a todos nuestros clientes para satisfacer todas sus necesidades y requerimientos, con el fin de garantizar su crecimiento y la de nuestra empresa.



MISSION

COLFAST is a brand specialized in fasteners for the furniture and wood industry, we distribute all our products throughout Colombia, the Caribbean and Central America. Our vision is to facilitate and make the work easier to our clients in their industrial process, providing them with excellent quality products, which include Coil Nails, Staplers and Brads.

COLFAST is committed to offer the best service and after sales service to all our customers in order to meet all their needs and requirements, guaranteeing their growth and ours.





SOMOS
we are

**MARCA
LIDER
EN POTENCIA
Y PRECISIÓN**

LEADING BRAND
IN POWER
AND PRECISION

VISIÓN

COLFAST en el año 2024 será reconocida como la marca líder en la fabricación y comercialización de fijaciones para la industria del mueble y la madera, ofreciendo productos con altos estándares de calidad a nivel nacional e internacional, en los sectores de embalaje, mueblería y construcción, con el fin de garantizar resultados óptimos para nuestros clientes.



VISION

COLFAST in the year 2024 will be recognized as the leading brand in the manufacture and distribution of fasteners for the furniture and wood industry, offering products with high end quality standards nationally and internationally, in the packaging, furniture and construction sectors , in order to guarantee optimal results for our customers.





COLFAST
CN70

COLFAST
N851

COLFAST
450

CN70 Clavadora en Banco
APLICACIONES: Fabricación y reparación de
bidones, embalajes y valas de madera. Aplicación
en general para la industria y la construcción.
ESPECIFICACIONES:
Peso: 1,87 kg. Capacidad de trabajo:
Caudal de clavos: 225 - 300 clavos/min.
Anchura de clavos: 2,8 - 2,9 mm.
Velocidad de clavos: 45 - 75 clavos/min.
Consumo de aire: 1,8 lpa/cm².

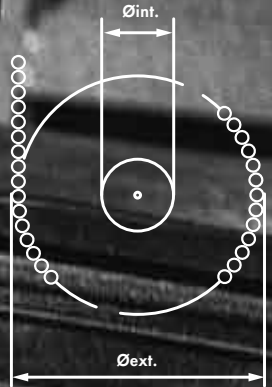

COLFAST
COLOMBIAN FASTENERS

NUESTROS PRODUCTOS

OUR
PRODUCTS

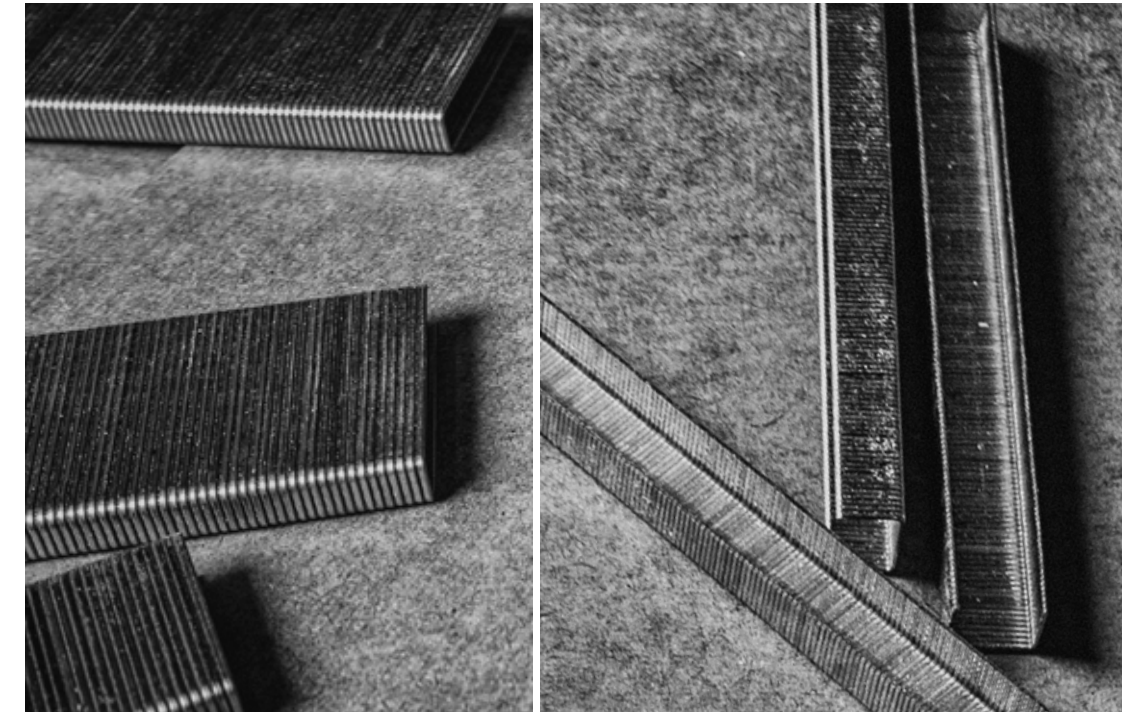
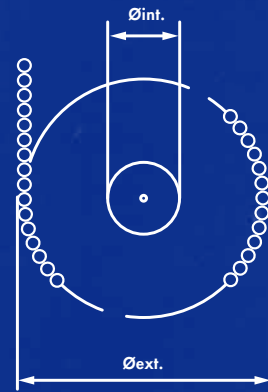

GRAPA / STAPLES

**1" / 1,5" /
2" / 2,5"**

80 / 10

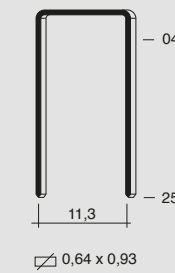
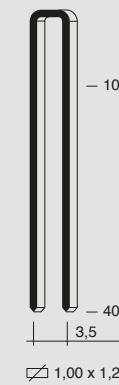

USOS / APPLICATIONS

-  **INDUSTRIA EN GENERAL**
INDUSTRY IN GENERAL
-  **EMBALAJE DE MADERA**
WOODEN PACKAGING
-  **CARPINTERÍA**
CARPENTRY
-  **PUERTAS**
DOORS
-  **EBANISTERÍA Y MUEBLES**
WOODWORK & FURNITURE
-  **COLCHONERÍA**
MATTRESS
-  **TAPICERÍA**
UPHOLSTERY

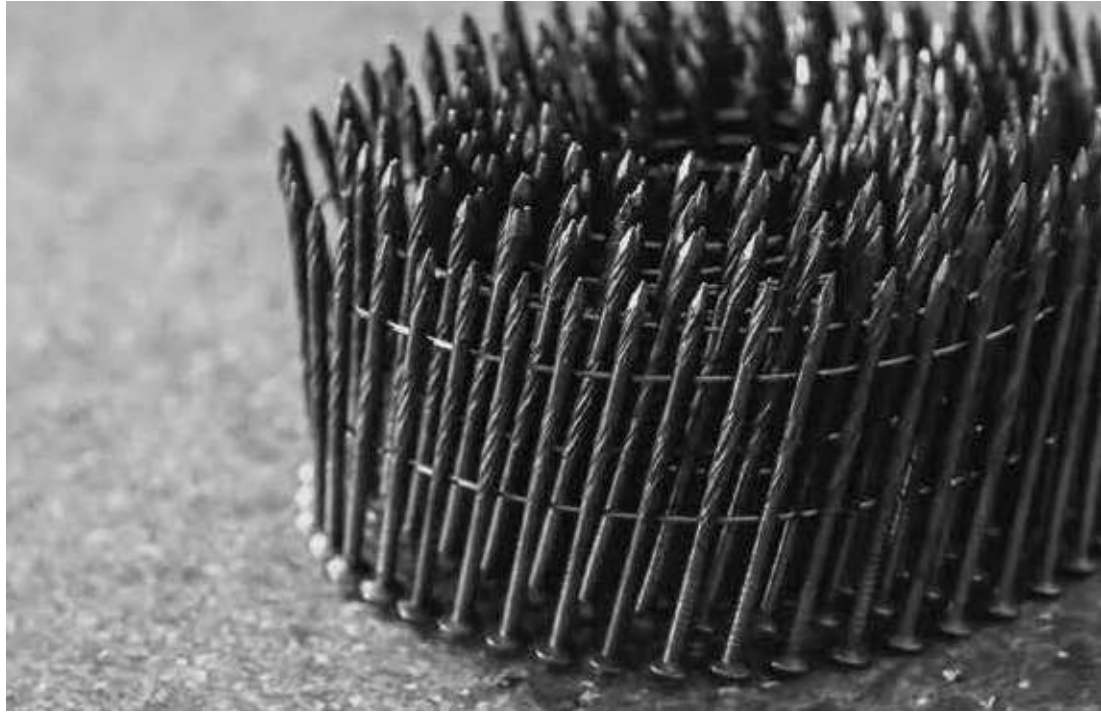

CLAVO / NAILS
2,0 / 2,2 /
2,3 / 2,5 /
2,8 / 3,1 mm.

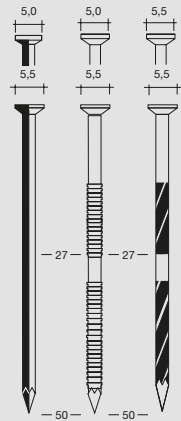

USOS / APPLICATIONS



PALETS
ESTIBAS



EMBALAJE DE MADERA
WOODEN PACKAGING



INDUSTRIA EN GENERAL
INDUSTRY IN GENERAL



CONSTRUCCIÓN
CONSTRUCTION

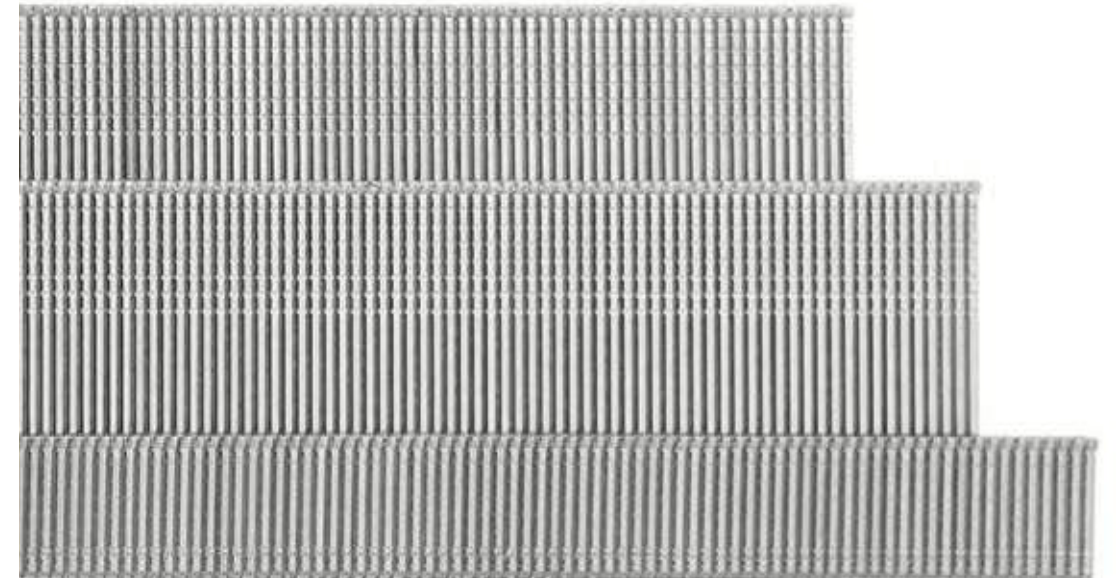

BRAD / BRAD
12 mm.

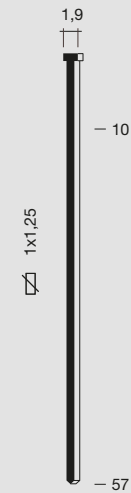

USOS / APPLICATIONS



PALETS
ESTIBAS



EMBALAJE DE MADERA
WOODEN PACKAGING



INDUSTRIA EN GENERAL
INDUSTRY IN GENERAL



CONSTRUCCIÓN
CONSTRUCTION



CN70

Dimensiones máquina <i>Dimensions</i>	(mm.)	306 x 128 x 315
Peso <i>Weight</i>	(kgs.)	3,500
Presión de trabajo <i>Work pressure</i>	(atm.)	6 ÷ 8
Capacidad de carga <i>Loading capacity</i>	(pcs.)	300
Medidas consumible <i>Consumable measures</i>	(mm.)	45 ÷ 70
Diametro <i>Diameter</i>	(mm.)	2,5 - 2,8

CLAVO/NAILS 2,3/2,5mm.

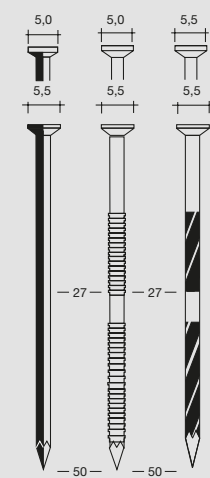

USOS / APPLICATIONS

-  **PALETS**
ESTIBAS
-  **EMBALAJE DE MADERA**
WOODEN PACKAGING
-  **INDUSTRIA EN GENERAL**
INDUSTRY IN GENERAL
-  **CONSTRUCCIÓN**
CONSTRUCTION



CN57

Dimensiones máquina <i>Dimensions</i>	(mm.)	270 x 131 x 283
Peso <i>Weight</i>	(kgs.)	2,870
Presión de trabajo <i>Work pressure</i>	(atm.)	5 ÷ 8,5
Capacidad de carga <i>Loading capacity</i>	(pcs.)	250 - 400
Medidas consumible <i>Consumable measures</i>	(mm.)	27 ÷ 58
Diametro <i>Diameter</i>	(mm.)	2,0 - 2,2

CN57

APLICACIONES: Fabricación y reparación de palets, bidones, embalajes y vallas de madera. Aplicaciones en general para la industria y la construcción.

ESPECIFICACIONES:

Peso	2,68 kgs. (Cuerpo de Aluminio)
Capacidad cargador	300 -350 Clavos
Diametro de clavo	2,1-2,3 mm.
Largo de clavo	25 - 57 mm.
Presión de trabajo	5 - 8,5 kgs./cm. ²

17-06-23

CLAVO/NAILS 2,0/2,2mm.

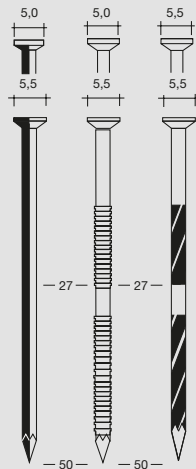

USOS / APPLICATIONS

-  **PALETS**
ESTIBAS
-  **EMBALAJE DE MADERA**
WOODEN PACKAGING
-  **INDUSTRIA EN GENERAL**
INDUSTRY IN GENERAL
-  **CONSTRUCCIÓN**
CONSTRUCTION



CN90B

Dimensiones máquina <i>Dimensions</i>	(mm.)	340 x 125 x 350
Peso <i>Weight</i>	(kgs.)	3,920
Presión de trabajo <i>Work pressure</i>	(atm.)	7 ÷ 8
Capacidad de carga <i>Loading capacity</i>	(pcs.)	300
Medidas consumible <i>Consumable measures</i>	(mm.)	50 ÷ 90
Diametro <i>Diameter</i>	(mm.)	2,5 - 3,1

CLAVOS/NAILS 2,5/2,8/3,1 mm.

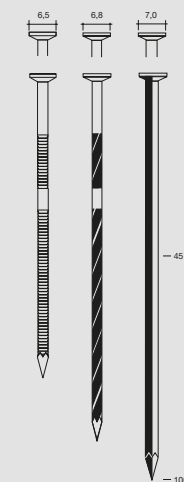

USOS / APPLICATIONS



PALETS
ESTIBAS



EMBALAJE DE MADERA
WOODEN PACKAGING



INDUSTRIA EN GENERAL
INDUSTRY IN GENERAL



CONSTRUCCIÓN
CONSTRUCTION



N851

Dimensiones máquina <i>Dimensions</i>	(mm.)	252 x 65 x 218
Peso <i>Weight</i>	(kgs.)	1,200
Presión de trabajo <i>Work pressure</i>	(atm.)	5 ÷ 8
Capacidad de carga <i>Loading capacity</i>	(pcs.)	100
Medidas consumible <i>Consumable measures</i>	(mm.)	27 ÷ 58
Diametro <i>Diameter</i>	(mm.)	13 ÷ 25

GRAPA / STAPLES 1" / 2"



USOS / APPLICATIONS



INDUSTRIA EN GENERAL
INDUSTRY IN GENERAL



EMBALAJE DE MADERA
WOODEN PACKAGING



CARPINTERÍA
CARPENTRY



PUERTAS
DOORS



EBANISTERÍA Y MUEBLES
WOODWORK & FURNITURE



CALZADO
FOOTWEAR



ESQUELETAJE
WOOD STRUCTURES



80/16-420

Dimensiones máquina <i>Dimensions</i>	(mm.)	230 x 46 x 156
Peso <i>Weight</i>	(kgs.)	0,900
Presión de trabajo <i>Work pressure</i>	(atm.)	5 ÷ 7
Capacidad de carga <i>Loading capacity</i>	(pcs.)	140
Medidas consumible <i>Consumable measures</i>	(mm.)	6 ÷ 16

GRAPA/STAPLE 80/10

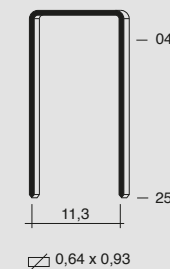

USOS / APPLICATIONS

-  **INDUSTRIA EN GENERAL**
INDUSTRY IN GENERAL
-  **EMBALAJE DE MADERA**
WOODEN PACKAGING
-  **CARPINTERÍA**
CARPENTRY
-  **PUERTAS**
DOORS
-  **EBANISTERÍA Y MUEBLES**
WOODWORK & FURNITURE
-  **COLCHONERÍA**
MATTRESS
-  **TAPICERÍA**
UPHOLSTERY



F50

Dimensiones máquina <i>Dimensions</i>	(mm.)	245 x 59 x 245
Peso <i>Weight</i>	(kgs.)	1,60
Presión de trabajo <i>Work pressure</i>	(atm.)	5 ÷ 7
Capacidad de carga <i>Loading capacity</i>	(pcs.)	200
Medidas consumible <i>Consumable measures</i>	(mm.)	15 ÷ 50

BRAD / BRAD 12mm.

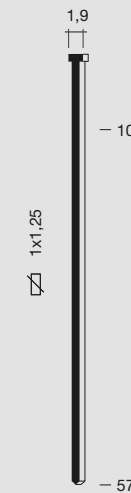

USOS / APPLICATIONS

-  **EBANISTERÍA Y MUEBLES**
WOODWORK & FURNITURE
-  **CALZADO**
FOOTWEAR
-  **MARQUETERÍA**
MARQUETRY
-  **CONSTRUCCIÓN**
CONSTRUCTION
-  **CARPINTERÍA**
CARPENTRY
-  **PUERTAS**
DOORS
-  **ATAUDES**
COFFINS

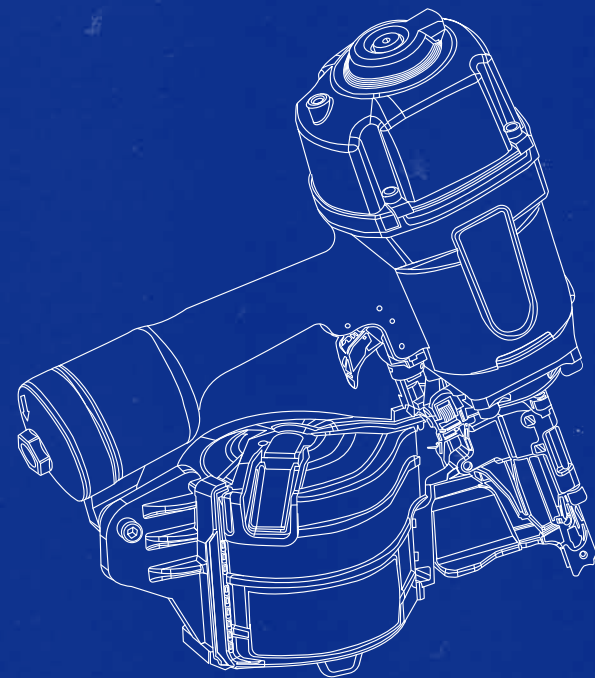

**CLAVO
NAIL**

**2,5/2,8/3.1
mm.**

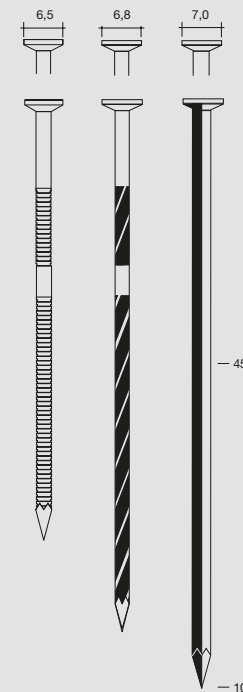

CNN-80



Dimensiones máquina <i>Dimensions</i>	(mm.)	307x132x362
Peso <i>Weight</i>	(kgs.)	3,980
Presión de trabajo <i>Work pressure</i>	(atm.)	6÷8
Capacidad de carga <i>Loading capacity</i>	(pcs.)	225-300
Medidas consumible <i>Consumable measures</i>	(mm.)	50÷80
Diametro <i>Diameter</i>	(mm.)	2,5-3,1

CN-80



Dimensiones máquina <i>Dimensions</i>	(mm.)	307x132x362
Peso <i>Weight</i>	(kgs.)	3,980
Presión de trabajo <i>Work pressure</i>	(atm.)	6÷8,5
Capacidad de carga <i>Loading capacity</i>	(pcs.)	225-300
Medidas consumible <i>Consumable measures</i>	(mm.)	50÷80
Diametro <i>Diameter</i>	(mm.)	2,5-3,1

CN-100



Dimensiones máquina <i>Dimensions</i>	(mm.)	336x156x417
Peso <i>Weight</i>	(kgs.)	5,300
Presión de trabajo <i>Work pressure</i>	(atm.)	7÷8
Capacidad de carga <i>Loading capacity</i>	(pcs.)	250
Medidas consumible <i>Consumable measures</i>	(mm.)	65÷100
Diametro <i>Diameter</i>	(mm.)	2,5-3,1

CLAVO/NAIL
3,4/3,8mm.

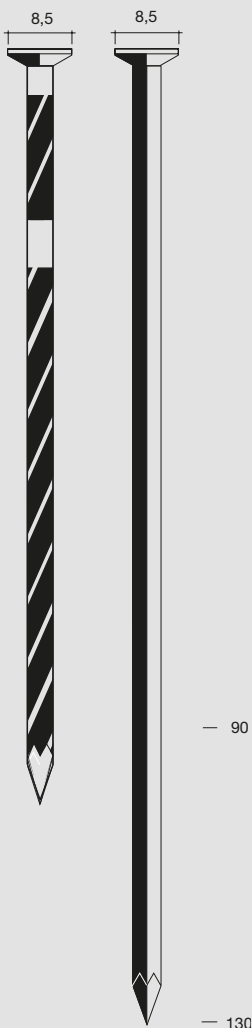

— 90

— 130

CN-130



Dimensiones máquina	(mm.)	354x149x473
<i>Dimensions</i>		
Peso	(kgs.)	5,700
<i>Weight</i>		
Presión de trabajo	(atm.)	6÷8,5
<i>Work pressure</i>		
Capacidad de carga	(pcs.)	180
<i>Loading capacity</i>		
Medidas consumible	(mm.)	90÷130
<i>Consumable measures</i>		
Diametro	(mm.)	2,4-3,8
<i>Diameter</i>		

CLAVO FCP
NAIL FCP



Detalle cabeza

MINI
1,8mm.

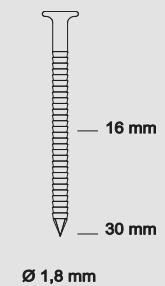

Ø 1,8 mm

CLAVO FCP
NAIL FCP

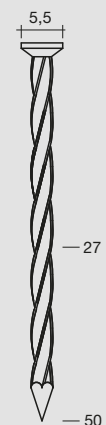

— 27

— 50

CN-238



Dimensiones máquina	(mm.)	217x106x249
<i>Dimensions</i>		
Peso	(kgs.)	1,200
<i>Weight</i>		
Presión de trabajo	(atm.)	5÷7
<i>Work pressure</i>		
Capacidad de carga	(pcs.)	200
<i>Loading capacity</i>		
Medidas consumible	(mm.)	17÷38
<i>Consumable measures</i>		

CNP-40M



Dimensiones máquina	(mm.)	248x111x285
<i>Dimensions</i>		
Peso	(kgs.)	1,260
<i>Weight</i>		
Presión de trabajo	(atm.)	5÷8
<i>Work pressure</i>		
Capacidad de carga	(pcs.)	325
<i>Loading capacity</i>		
Medidas consumible	(mm.)	16÷40
<i>Consumable measures</i>		

CN-650M



Dimensiones máquina	(mm.)	277x132x380
<i>Dimensions</i>		
Peso	(kgs.)	3
<i>Weight</i>		
Presión de trabajo	(atm.)	6÷8
<i>Work pressure</i>		
Capacidad de carga	(pcs.)	200
<i>Loading capacity</i>		
Medidas consumible	(mm.)	27÷50
<i>Consumable measures</i>		

CLAVOS/NAILS
2,1 - 2,8mm.

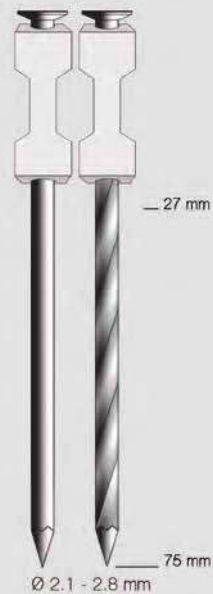

CLAVOS/NAILS
3,8mm.



CNP-50.1



Dimensiones máquina	(mm.)	310x146x305
<i>Dimensions</i>		
Peso	(kgs.)	2,100
<i>Weight</i>		
Presión de trabajo	(atm.)	5÷8
<i>Work pressure</i>		
Capacidad de carga	(pcs.)	325
<i>Loading capacity</i>		
Medidas consumible	(mm.)	27÷50
<i>Consumable measures</i>		

CNP-65.1



Dimensiones máquina	(mm.)	318x146x320
<i>Dimensions</i>		
Peso	(kgs.)	2,100
<i>Weight</i>		
Presión de trabajo	(atm.)	5÷8
<i>Work pressure</i>		
Capacidad de carga	(pcs.)	325
<i>Loading capacity</i>		
Medidas consumible	(mm.)	27÷65
<i>Consumable measures</i>		

CNP-75.1



Dimensiones máquina	(mm.)	296x154x358
<i>Dimensions</i>		
Peso	(kgs.)	2,83
<i>Weight</i>		
Presión de trabajo	(atm.)	5÷8
<i>Work pressure</i>		
Capacidad de carga	(pcs.)	325
<i>Loading capacity</i>		
Medidas consumible	(mm.)	32÷75
<i>Consumable measures</i>		

HN-500



Dimensiones máquina	(mm.)	464x180x349
<i>Dimensions</i>		
Peso	(kgs.)	7,00
<i>Weight</i>		
Presión de trabajo	(atm.)	5÷9
<i>Work pressure</i>		
Capacidad de carga	(pcs.)	150
<i>Loading capacity</i>		
Medidas consumible	(mm.)	80÷130
<i>Consumable measures</i>		

CLAVOS/NAILS
2,8 - 4,6mm.

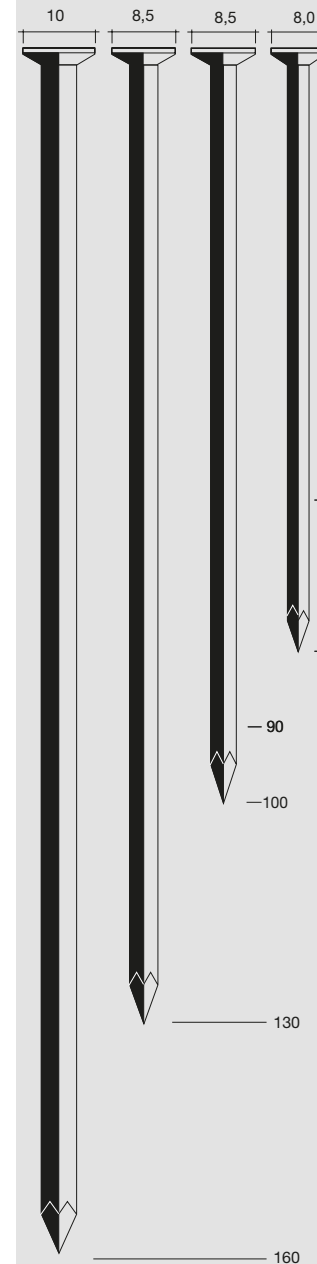

SN-100



Dimensiones máquina	(mm.)	515x110x360
<i>Dimensions</i>		
Peso	(kgs.)	3,650
<i>Weight</i>		
Presión de trabajo	(atm.)	5÷8
<i>Work pressure</i>		
Capacidad de carga	(pcs.)	66
<i>Loading capacity</i>		
Medidas consumible	(mm.)	65÷100
<i>Consumable measures</i>		
Diametro	(mm.)	2,8-3,4
<i>Diameter</i>		

S-130



Dimensiones máquina	(mm.)	620x150x505
<i>Dimensions</i>		
Peso	(kgs.)	5,200
<i>Weight</i>		
Presión de trabajo	(atm.)	8
<i>Work pressure</i>		
Capacidad de carga	(pcs.)	70
<i>Loading capacity</i>		
Medidas consumible	(mm.)	90÷130
<i>Consumable measures</i>		
Diametro	(mm.)	3,4-4,6
<i>Diameter</i>		

S-160



Dimensiones máquina	(mm.)	588x159x505
<i>Dimensions</i>		
Peso	(kgs.)	6,700
<i>Weight</i>		
Presión de trabajo	(atm.)	8
<i>Work pressure</i>		
Capacidad de carga	(pcs.)	45
<i>Loading capacity</i>		
Medidas consumible	(mm.)	100÷160
<i>Consumable measures</i>		
Diametro	(mm.)	3,4-4,6
<i>Diameter</i>		

CLAVOS/NAILS
2,5 - 3mm.

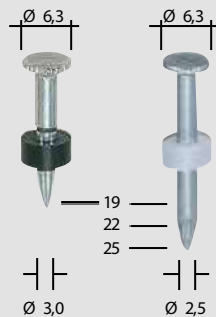

HN-25C



Dimensiones máquina	(mm.)	306x82x306
<i>Dimensions</i>		
Peso	(kgs.)	2
<i>Weight</i>		
Presión de trabajo	(atm.)	12÷23
<i>Work pressure</i>		
Capacidad de carga	(pcs.)	100
<i>Loading capacity</i>		
Medidas consumible	(mm.)	19÷25
<i>Consumable measures</i>		
Diametro	(mm.)	2,5-2,9
<i>Diameter</i>		

CLAVOS/NAILS
2,5 - 3,3mm.



HN-90



Dimensiones máquina	(mm.)	306x82x306
<i>Dimensions</i>		
Peso	(kgs.)	2,400
<i>Weight</i>		
Presión de trabajo	(atm.)	12÷23
<i>Work pressure</i>		
Capacidad de carga	(pcs.)	250
<i>Loading capacity</i>		
Medidas consumible	(mm.)	45÷90
<i>Consumable measures</i>		
Diametro	(mm.)	2,5-3,3
<i>Diameter</i>		

CLAVOS/NAILS
2,9-3,8mm.

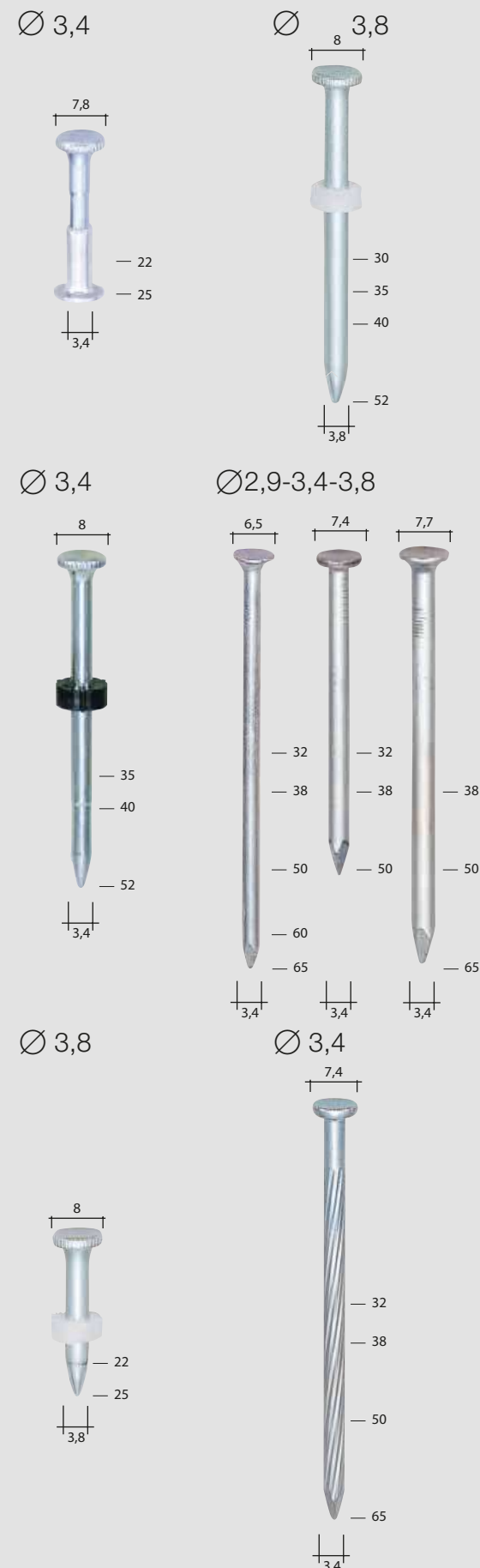

HN-120



Dimensiones máquina	(mm.)	315x85x400
<i>Dimensions</i>		
Peso	(kgs.)	2,900
<i>Weight</i>		
Presión de trabajo	(atm.)	15÷23
<i>Work pressure</i>		
Capacidad de carga	(pcs.)	50
<i>Loading capacity</i>		
Medidas consumible	(mm.)	22÷65
<i>Consumable measures</i>		
Diametro	(mm.)	2,9-3,8
<i>Diameter</i>		

CONSUMIBLE SIERRA

SAW CONSUMABLE



- MM02100151
- MM02100140
- MM02100143
- MM02100149
- MM02100141
- MM02100142

COLFAST VR 3070 LT



Longitud total	(mm.)	485x99x181
Total length		
Peso	(kgs.)	4,4
Weight		
Consumo potencia	(W.)	1.510
Power consumption		
Carrera por minuto	(cpm.)	2.800
Run per minute		
Carrera por longitud	(mm.)	32
Run per length		
Longitud cable	(m.)	4,4
Cable length		

SIERRAS SABLE / SAW BLADES

MM02100151

Longitud / length	(mm.)	200
Grueso / thickness	(mm.)	1,3
TPI / TPI		8-12
Calidad / quality		Bimetal · 8% Cobalto/cobalt

MM02100140

Longitud / length	(mm.)	200
Grueso / thickness	(mm.)	1,3
TPI / TPI		10-14
Calidad / quality		Bimetal · 8% Cobalto/cobalt

MM02100143

Longitud / length	(mm.)	225
Grueso / thickness	(mm.)	0,9
TPI / TPI		10-14
Calidad / quality		Bimetal · 8% Cobalto
Nota / note		Especial Europalet

MM02100149

Longitud / length	(mm.)	300
Grueso / thickness	(mm.)	1,3
TPI / TPI		8-12
Calidad / quality		Bimetal · 8% Cobalto/cobalt

MM02100141

Longitud / length	(mm.)	300
Grueso / thickness	(mm.)	1,3
TPI / TPI		10-14
Calidad / quality		Bimetal · 8% Cobalto/cobalt

MM02100142

Longitud / length	(mm.)	200
Grueso / thickness	(mm.)	0,9
TPI / TPI		10
Calidad / quality		Bimetal · 8% Cobalto/cobalt
Nota / note		Punta redonda / round point



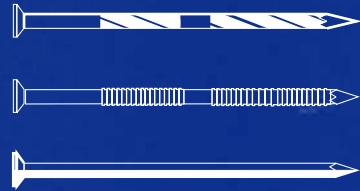

CONTACTO CONTACT

COL
+57 (5) 339 5617
CALLE 41 # 52 - 75
BARRANQUILLA, ATLÁNTICO
080003

MEX
+52 1 (222) 583 9463
+52 1 (222) 493 6145
CALZADA ZAVALA #3913 - 1A
COLONIA SANTA CRUZ BUENAVISTA
PUEBLA; PUEBLA
CP: 72150

USA
+1 (305) 205 7616
MIAMI
410 CADIMA AVENUE
CORAL GABLES
FL 33134

ADMON@COLFAST.COM.CO
WWW.COLFAST.COM.CO

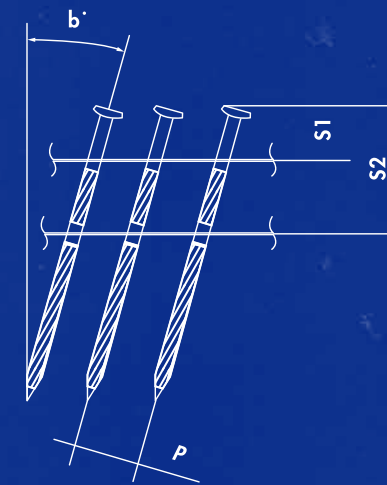

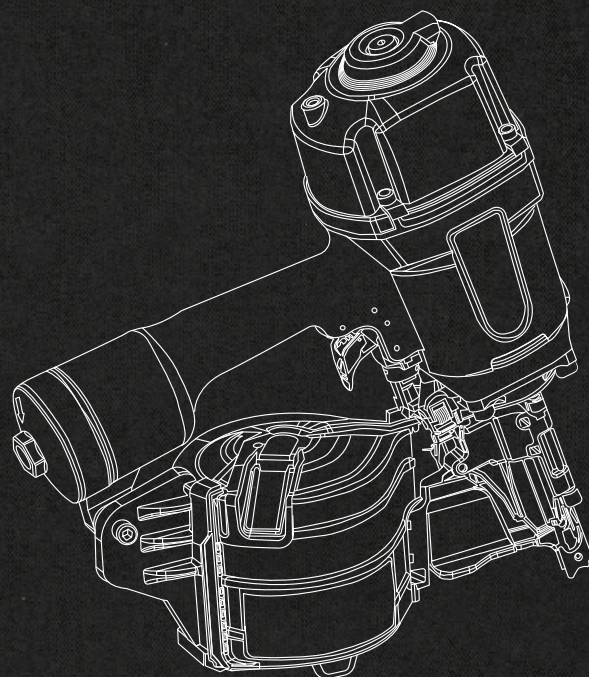

WWW.COLFAST.COM.CO